



Pijpdiameter (mm)
Pipe diameter (mm)
Diamètre buse (mm)
Abgasstutzen (mm)



Efficiëntie
Efficiency
Efficacité
Effizienz



Gewicht (kg)
Weight (kg)
Poids (kg)
Gewicht (kg)



Vermogen output (kW)
Capacity output (kW)
Puissance output (kW)
Leistung output (kW)

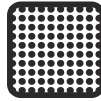

Binnenwerk vermiculiet
Vermiculite panels inside
Intérieur vermiculite
Innenbekleidung Vermiculiet



Bovenaansluiting
Connection top
Raccordement dessus
Anschluss oben



Externe luchttoevoer
External air supply
Prise d'air extérieure
Externer Luftanschluss

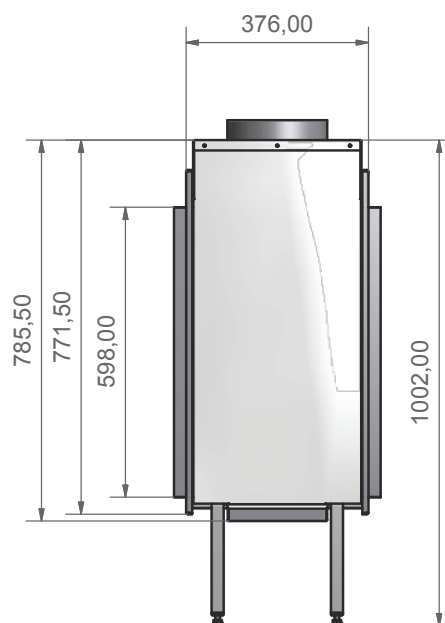
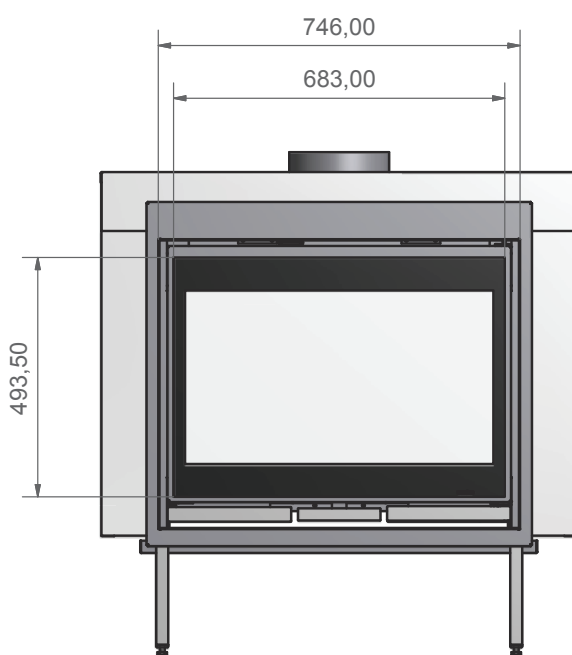
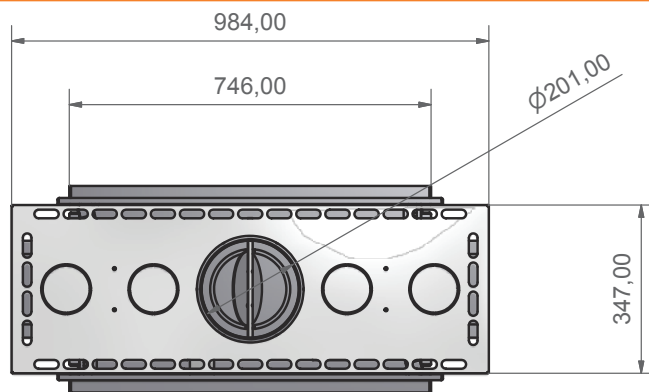

wanders
fires & stoves

Wanders fires & stoves | Tel: +31(0)315 - 386 414
Amtweg 4 | Fax: +31 (0)315 - 386 201
7077 AL NETTERDEN | info@wanders.nl
The Netherlands | www.wanders.nl